

Cod	48SHT9803A1
Familie	TRITUS Large
Gama	Apa de canalizare cu toicator
Tipologie	Submeribile

Extra UE Only	Nu
Utilizari	Civil Domestic

Limite de utilizare

Tip lichid	Apa de canalizare
Temperatura minima a lichidului	0 °C
Temperatura maxima a lichidului	40 °C
Continut maxim de clor	- ppm
Continut maxim de nisip	- ppm
Inaltimea maxima de aspiratie	0 m
Adancimea maxima de imersie	10,00 m
Temperatura ambientala maxima	- °C
Temperatura ambientala minima	- °C
Presiune maxima de exercitiu	- bar

Punct de lucru

Debit actual	0,000 l/min
Inaltimea de lucru	0,000 m

Placuta de identificare a pompei

Debit	20 - 275 l/min
Inaltime	35 - 2 m
Inaltime maxima	36.5 m
Inaltime minima	2 m
Indice de eficienta minima	-

Placuta de identificare a motorului

Tensiune	220-230 V
Faza	1
Frecventa	50 Hz
Viteza de rotatie	2900 rpm
Putere nominala	2,20 kW
Curent nominal	14 A
Putere abosrbita P1	3,00 kW
Gradul de eficienta	Undefined
Capacitate condensator	60 µF
Tensiunea condensatorului	450 V
Clasa de izolare	F
Grad de protectie IP	X8

Norme de executie și siguranță

electropomoe echipate:

- cablu de alimentare 10 m
- tablou electric pentru verisunile monofazice

EN 60335-1, IEC 60335-1, CEI 61-150

EN 60034-1, IEC 60034-1, CEI 2-3

Conexiuni

Tipul conexiunii	Flangiate PN 10 EN 1092-2 e filetate Gas
Dimensiunea guri aspiratie	-
Dimensiunea guri refulare	40

Date de intrare

Debit nominal solicitat	0,000 l/min
Inaltime solicitata	0,000 m
Inaltimea sistemului geodezic	0,000 m
Pierderi de sarcina ale sistemului	0,000 m
NPSH disponibil	0,000 m
Lichid	Water
Temperatura	20 °C
Densitate	998,1 kg/m ³
Vascozitate cinematica	1,00 mm ² /s
Presiunea aburului	2.318 Pa

Alte date despre pompa

Nivel maxim de presiune acustica 1m	- dBA
instalare orizontala	Nu
Trecerea corpurilor solide	- mm

Prestatii

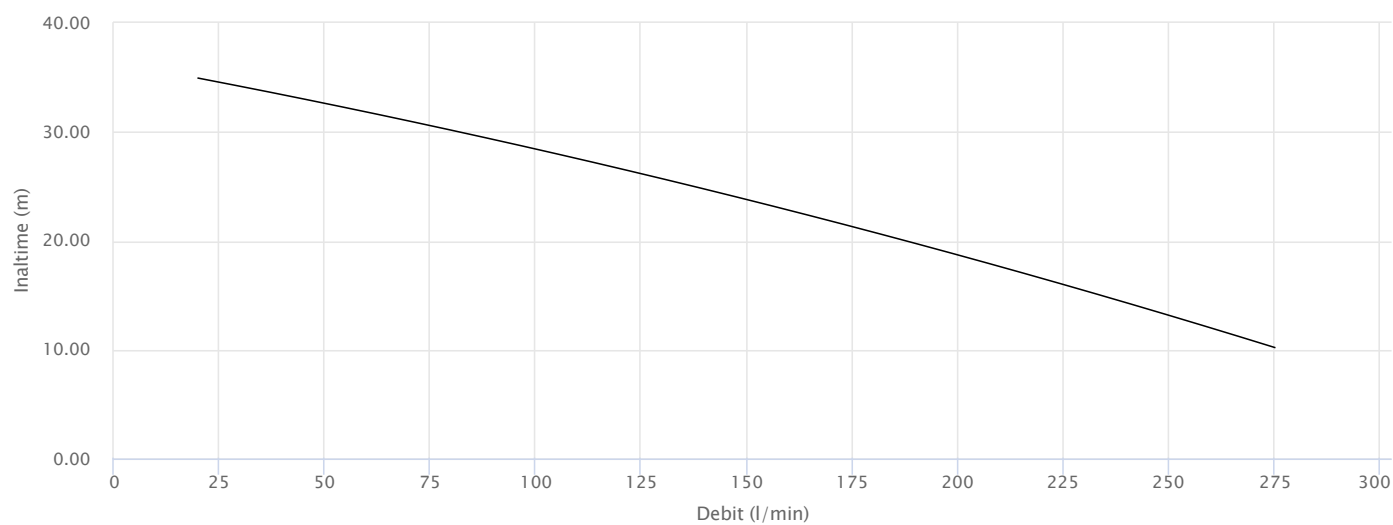

Constructie

Rulmenti

Rulment motor -partea pompei	3305 B-2RS-EA5
Rulment motor-partea opusa	6204 ZZ-EA3

Presetupa rotor

Tip presetupa	Presetupa mecanica dubla separata de o camera de ulei
Model motor lateral	STA-24
Diametru MS	24
Inel fix MS	Ceramica
Inel rotativ MS	Grafit
Elastomer MS	NBR
Model pompa laterala	STA-22
Diametru PS	22
Inel fix PS	Carbura de siliciu
Inel rotativ PS	Carbura de siliciu
Elastomer PS	NBR

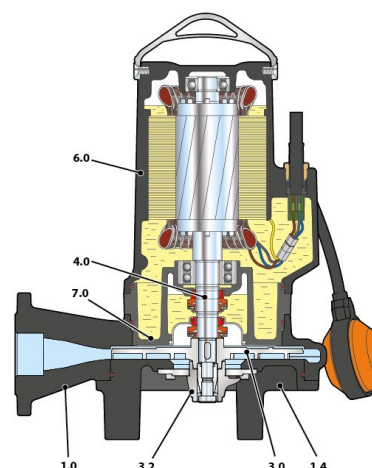

Material

1.0 - Corp pompa	Fonta GJL 200 EN 1561
1.4 - Baza	Fonta GJL 200 EN 1561
3.0 - Turbina	Otel inoxidabil 1.4301 (AISI 304)
3.2 - Tocator	Otel inoxidabil ENEN 1.4125 (AISI 440C) Intarit
4.0 - Rotor pompa	Otel inoxidabil EN 1.4057 (AISI 431)
6.0 - Carcasa motor	Fonta GJL 200 EN 1561
7.0 - Lanterna	Fonta GJL 200 EN 1561

Dimensiuni

DN2	a	b	c	d	e	h	h1	p	x	
	[mm]									Kg
40	203	126	256	95	130	480	90	800	800	50,4

